

CP205 – M0

(With/without cutter option)

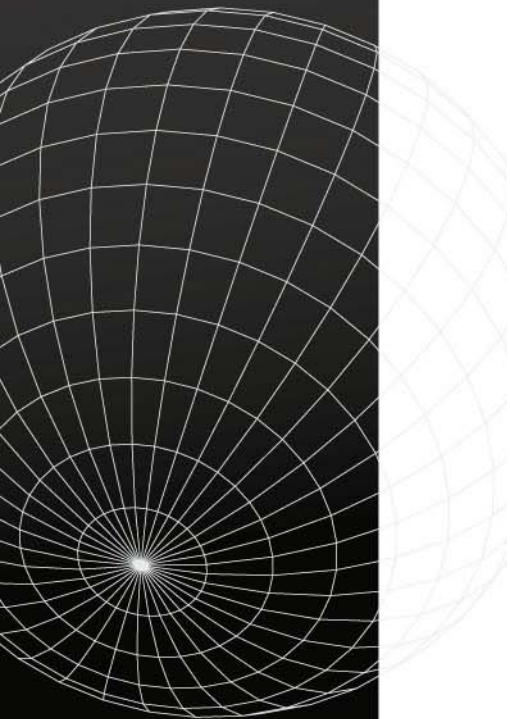

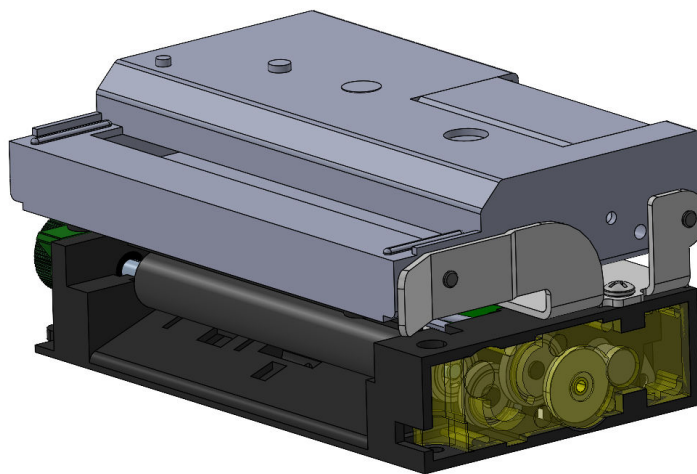
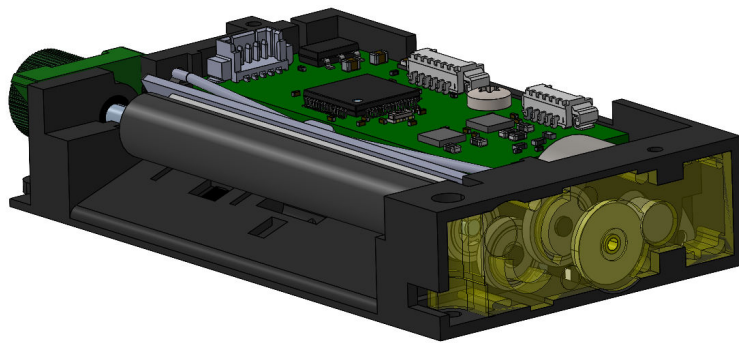
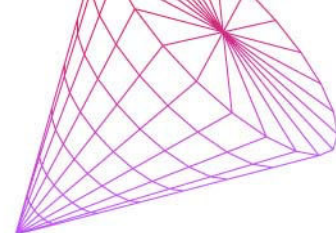

TABLE OF CONTENTS

1.	Table of contents	1
2.	Revision history.....	2
3.	General features.....	3
3.1	Product description	4
4.	General specifications.....	5
5.	Printer device interconnections	7
5.1	Power supply connector.....	8
5.2	RS232 communication connector	9
5.3	USB communication connector.....	10
5.4	Switch/Led/ connector	10
6.	Printer device operations	12
6.1	Self-test mode	12
6.2	Paper loading	13
6.3	Operating Control codes.....	13
7.	Ordering codes.....	14
8.	Accessories	15

\

<http://www.aps-printers.com/>

This manual provides complete information about A.P.S CP205-M0.

A.P.S reserves the right to make changes without notice to the product to improve reliability, function or design.

A.P.S does not assume any liability arising out of the application or use of the product or circuit described herein.

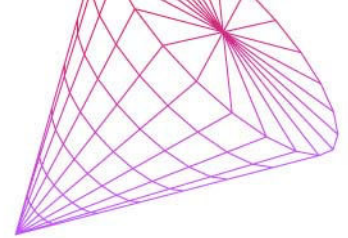

2. REVISION HISTORY

REV.	DATE	PAGE	REVISION ITEM	AUTHOR
Prel.1	13/04/2021	-	First issue.	TT
Prel.2	20/01/2023	All	Document dedicated to CP205-M0.	TT
Rev.A	19/07/2023	All	Official release.	TT

- This manual provides complete technical information for the CP205-M0 "Compact Printer 2" 5V".
- For customized mechanisms, A.P.S. supplies documentation in addition to the present specification.
- The present specification is valid also for customized types, where the different condition has no effect on common data (e.g.: different colour of case parts).
- A.P.S. reserves the rights to make changes to the product, without notice, to improve reliability, function or design.
- A.P.S. does not assume any liability arising from the application or the use of product or circuits described herein.
- The warranty terms of the product are described in a separate document; please contact A.P.S. to obtain this document.

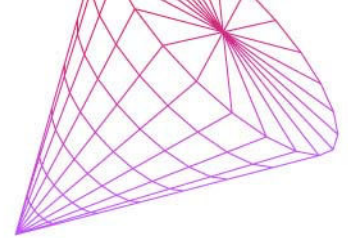

3.1 GENERAL FEATURES

The CP205-M0 printer is the first integrated printer in the size of a mechanism. This printer includes one CP205 print mechanism with an integrated controller board (enhanced version of the previous HRS one) operating from a serial communication. Thanks to its optimization the volume of the complete printer is same as the print mechanism alone.

- **Ultra-compact printers**
 - CP205-M0 *Total size W88 x D54 x H16 mm*
 - CP205-M0-GCA *Total size W94 x D61 x H37 mm*
- **Fully hot plug printers**
- **Software programmable consumption**
 - Dynamic division and high speed (up to 90mm /s)*
- **Full control over printing quality/speed**
 - Speed clamping, acceleration smoothing... via control codes*
- **External pluggable switches and LED for easy integration**
- **Single power supply**
 - From 5 Volts to 8.5 Volts*
- **Communication ports**
 - **USB2.0** (Full speed)
 - **RS232** (Default 9600 Bds, speed up to 115 200 Bds)
- **Three internal fonts**
 - Easy font update*
- **Powerful Text Printing Modes**
 - Up to 48 characters per line.*
 - Horizontal (normal or rotated 180°)*
 - Double and Quadruple width and height printing*
 - Inverse video*
 - 3 justifications (centered, right, left)*
- **Powerful Graphic Modes**
 - Variable width and offset*
 - Double width and height*
- **Hole / Mark Detection**
- **Supports reflective and transmissive optocouplers**
- **Cutter driving**
 - Guillotine cutter type*
- **10 Barcodes**
 - Normal and rotated 90° for 1D bar codes, QR 2D bar code*
- **Setup parameters saved in flash are recovered at next power-up**
 - One simple commands saves all important parameters*
- **Supports easy single-sheet insertion /ejection**
- **Windows and Linux drivers available**
- **Easy firmware upgrades** (please contact A.P.S)

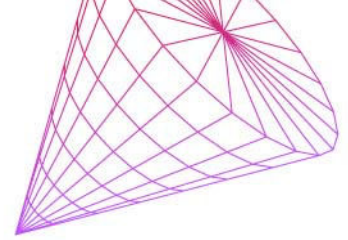

3.1 PRODUCT DESCRIPTION

The sections that form the CP205 printer are described below:

1. Printer mechanism, paper introduction Bottom Loading (BL) or Front Loading (FL)
2. Platen roller
3. Thermal print head module (TPH)
4. MO controller board
5. Stepper motor for paper feed
6. Gear train
7. Paper opto sensor (2 positions according to paper loading side)
8. Lever to lift TPH
9. Cutter module

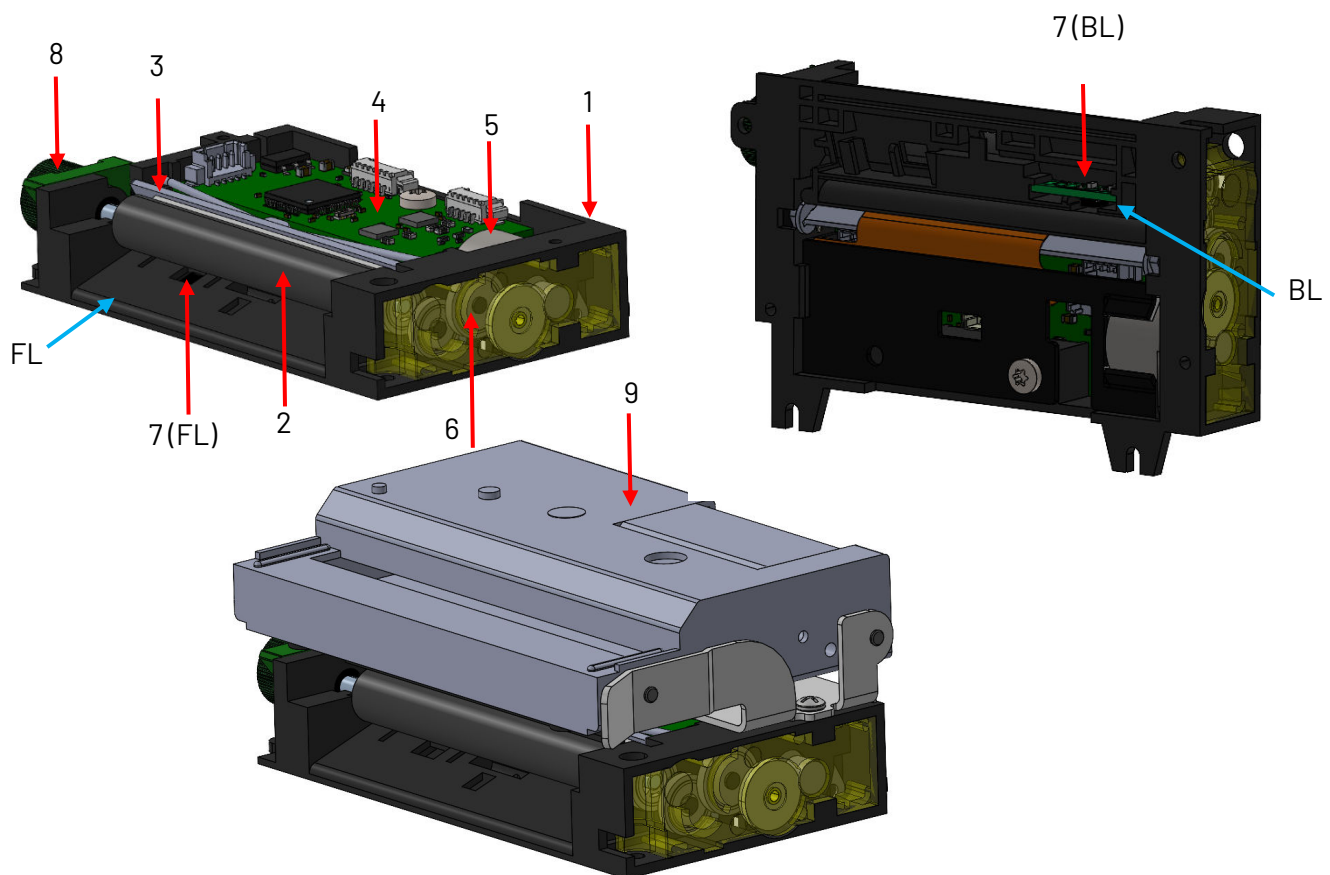

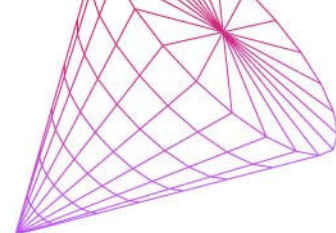

4. GENERAL SPECIFICATIONS

ITEM	SPECIFICATION
Printing method	Thermal dot-line printing
Dimensions WxDxH (mm)	CP205-M0 88 x 54 x 16 CP205-M0-GCA 94 x 61 x 37
Weight (g)	~ 60 (210 with GCA)
Total number of dots	384
Average dot resistance (ohm)	176 Ω
Dot density (dots/mm)	8
Paper width (mm)	58 +0/1
Printing width (mm)	48 mm (centered on paper)
Heat element pitch (mm)	0,125
Paper feed pitch (mm)	0,125
Paper feed tension (g)	50 or more
Paper hold tension (g)	80 or more
Max paper thickness (µm)	80
Recommended papers <i>(Equivalent types can be used)</i>	JUJO-AF50KS-E (standard grade) JUJO-AF50KS-E3 (high sensitivity) Equivalent types can be used
Max printing speed (mm/s)	90
Paper detection	Opto sensor*
Voltage range (Volts)	From 5V to 8,5 V
Current consumption** (Amps) <i>(Max instantaneous value @5V - Full text lines)</i> <i>Starting value is when only paper feeding</i>	From 1,5A to 5A
Operating temperature*** (°C)	-10°C to +60°C (no condensation)
Operating humidity (RH%)	20 to 85 (no cond.)
Storage temperature (°C)	-40°C to +85°C (no cond.)
Storage humidity (RH%)	10 to 90 (no cond.)
EMC standard	Designed to comply with FCC/CE Class B

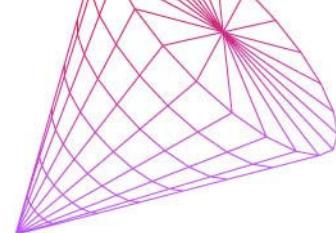

PRINTER LIFE			
	Durability	Basic conditions	Maximum variation
TPH pulse resistance	100 million pulses	- Room temp: \approx 20-25°C	Max 15% in resistance value (Ω) of any dot, from its initial value
Abrasion/Wear resistance	100 km of paper (printing duty 12,5%)	- Head temp: 65°C max Rated energy	

- * No paper detection could mean two things: the cover is open or no paper in the printer
- ** Power consumption can be adjusted / limited through control sequences
- *** Beyond the range of operating temperature from +5°C to +40 °C TPH's printing quality may be affected

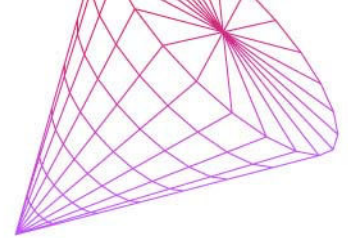

5. PRINTER DEVICE INTERCONNECTIONS

This printer is fully hot pluggable: any connector hereafter can be connected or disconnected without damaging the printer. For further detail please refer to the drawing attached to back of this specification for connector positions.

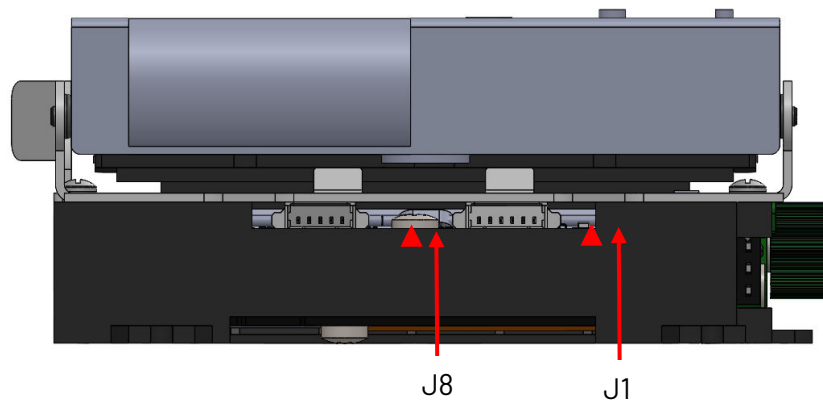

▲ : indication pin n°1

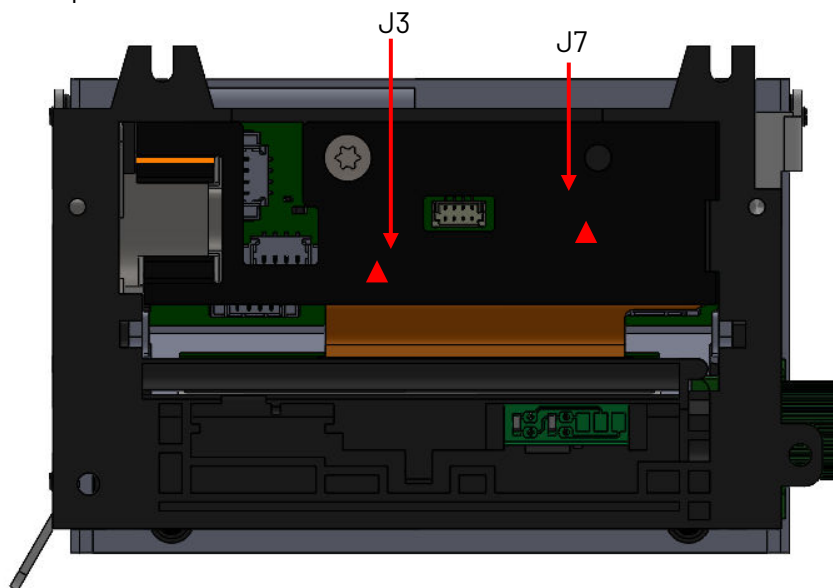

Reference	Location	Type	Description
J1	Top	Molex - 53261-0671	Power supply
J3	Bottom	Molex 53398-0471	Switch/Led connector
J7	Bottom	Chyao Shiunn JS-1254-04	USB communication
J8	Top	Molex - 53261-0571	RS232 serial communication

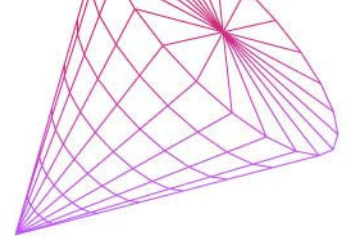

5.1 POWER SUPPLY CONNECTOR

Connector J1: MOLEX 53261-0671 series, 6 contacts 1.25 mm pitch (compatible with MOLEX female 51021 series). Power supply (VH) is from 5V to 8,5V DC. Maximum current is 5A @ 5V (peak for 3 ms)

PIN NUMBER	SIGNAL NAME
1	VH
2	VH
3	VH
4	GND
5	GND
6	GND

IMPORTANT NOTES:

- Wires AWG28 must be used in order to avoid current losses.
- During firmware updating, handshaking is automatically set in hardware mode and so all signals should be connected.

\

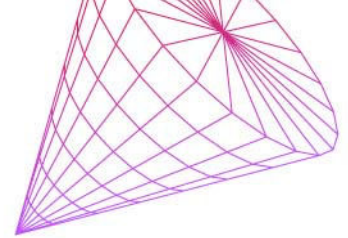

5.2 RS232 COMMUNICATION CONNECTOR

Connector J8: MOLEX 53261-0571, 5 contacts 1.25 mm pitch (compatible with MOLEX female 51021 series).

PIN NUMBER	SIGNAL NAME
1	GND
2	Transmit data (TxD, printer output)
3	Receive data (RxD, printer input)
4	CTS or RTS (printer handshaking input, only managed during firmware updating)
5	RTS or DSR (printer handshaking output)

Couple of signals from pins 4 and 5 should be considered as “CTS and RTS” or “DSR and DTR” in function of host handshaking implementation. They are basically managed only in hardware handshaking mode. When printer FIFO is full, RTS (or DTR) signal is set to logical level “1” to point out to host that sending should be stopped otherwise data will be lost (handshaking if OFF). As soon as the signal returns to logical level “0” (free space in printer FIFO), host sending can resume (handshaking is ON).

IMPORTANT NOTES: During firmware updating, handshaking is automatically set in hardware mode and so all signals should be connected.

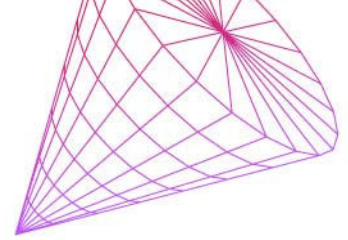

5.3 USB COMMUNICATION CONNECTOR

Connector J7: Chyao Shiunn JS-1254-04, 4 contacts 1 mm pitch (compatible with *CHYAO SHIUNN JS-1253 series or JST SHR series*).

PIN NUMBER	SIGNAL NAME
1	Vbus
2	D-
3	D+
4	GND

5.4 SWITCH/LED/ CONNECTOR

Connector J3: MOLEX 53398-0471 series, 4 contact 1.25 mm pitch (compatible MOLEX female 52021 series.)

PIN NUMBER	SIGNAL NAME
1	GND
2	ON/OFF Line Switch
3	Paper Feed Switch
4	Status LED (anode)

This connector allows you to design a remote interface "Paper Feed" button, "ON/OFF Line" button and "Status" LED.

External circuitry is as following:

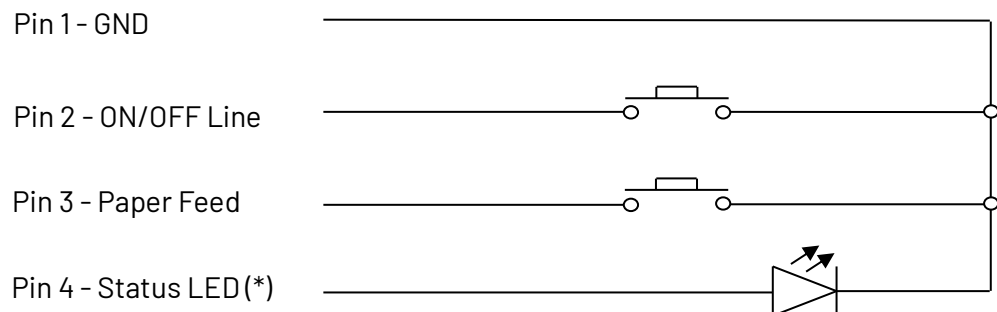

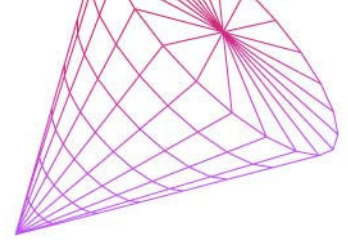

(*) A serial resistor (180 ohms) is on the printer, setting the LED current at about 5mA. In addition, an on-board status led is also present near power supply connector.

The standard A.P.S keyboard gathers user buttons and status LED.
 During normal board operation, pressing paper feed switch triggers a paper feed sequence.
 During normal board operation, pressing ON/OFF line switch continuously during more 3s triggers a hardware reset.

STATUS Led indicates the current state of the board:

```
"monitor":           {"pattern":"0xFFFFFFFF"},
"idle":              {"pattern":"0x10000000"},
"busy":              {"pattern":"0xFFFFFFFF"},
"paper loading":     {"pattern":"0xFFFF0000"},
"presentation(ticket at the exit)": {"pattern":"0xFF0F0000"},
```

Errors:

```
"temperature":      {"pattern":"0xCCCCCCCC"},
"head_up":          {"pattern":"0xF0F0F000"},
"power_supply":     {"pattern":"0xCC00CC00"},
"eop":              {"pattern":"0xF0F0F0F0"},
"jam":              {"pattern":"0xFF0F0F00"}
```

Each **Pattern** is corresponding to 32 x 64 ms, bit 1 means led is "on" during 64 ms

For example:

Board state	LED blink pattern
Online ("idle mode")	One short flash "on" (64 ms) every 2 sec
Printing (busy)	Always "on" (except if error occurs)
Paper stop – printer head up (cover is open)	Three flashes "on" 256 ms/ "off" 256 ms every two seconds
Paper stop – end of paper	Flashing "on" 256 ms/ "off" 256 ms...
Jam detection (paper loop detected)	One long flash (512 ms), 2 short flashes (256 ms)...
Monitor mode	"on" during 2sec, "off" during 64 ms...

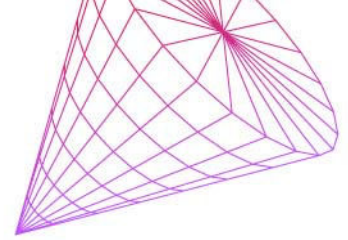

Notes:

- After self-test running, setup parameters return to their latest saving values.
- During self-test running, communication is disabled. Basically, received data are not buffered (in waiting state if USB). Only real time requests are processed (see section 6.5 for further details).

6.2 PAPER LOADING

Paper loading can be achieved by two different methods:

- **Automatic paper loading:** With the green head-up lever in the down position, insert the paper inside the printer, and then the roller will automatically feed the paper for about 40 mm. If the printer has a cutter, the cutter will cut the paper after the loading. The printer is then ready to print. This function can be achieved only if power supply is more than 5 volts. In mark detection mode, the paper is fed forward to the TOF position.
- **Manual paper loading:** Put the green head-up lever in the up position. Manually feed the paper into the printer until it exits between the thermal head and the roller. Turn the green lever to the head-down position. Now the printer is ready to print.

6.3 OPERATING CONTROL CODES

Control codes are non-printable characters or sequences of characters that control the operation of the printer. Please refer to the programming manual of the M0 driver board architecture for the detail of the corresponding CTRL sequence

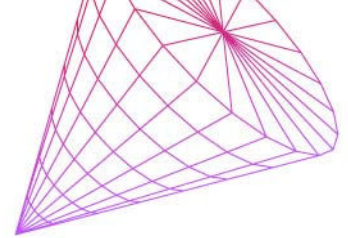

7. ORDERING CODES

PRODUCT NAME	ORDERING CODE
CP205-M0-BL COMPACT PRT 2" 5V	90CP2043Xxxxx
CP205-M0-FL COMPACT PRT 2" 5V	90CP2044Xxxxx

PRODUCT NAME	ORDERING CODE
CP205-M0-GCA-BL COMPACT PRT 2" 5V	90CP2033Xxxxx
CP205-M0-GCA-FL COMPACT PRT 2" 5V	90CP2034Xxxxx

X: indicating the printer revision
xxxx: indicating the firmware revision
GCA: with Guillotine Automatic Cutter

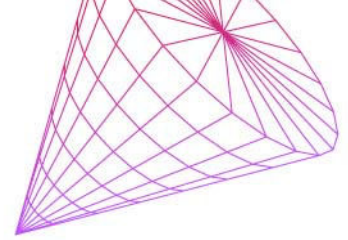

8. ACCESSORIES

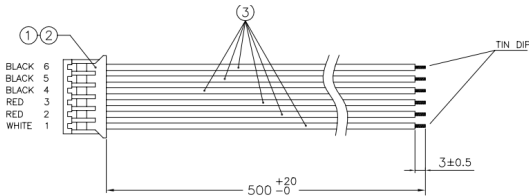
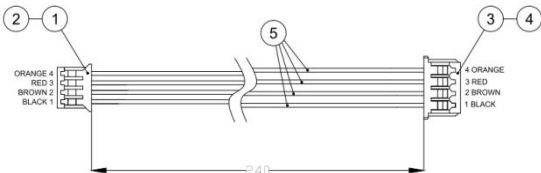
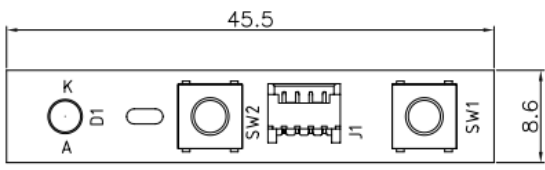
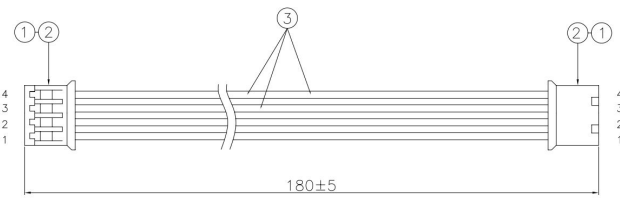
Description	Ordering Code
<p>Cable power supply L=500 mm CP-MRS Molex 6 pins pitch 1,25</p> 	91301306
<p>Cable USB</p> 	91301329
<p>"2 switches/LED" keyboard</p> 	91311033
<p>Keyboard cable (L=180mm)</p> 	91301104